

MARINE PRESSURE TRANSMITTER

Swiss based Trafag is a leading international supplier of high quality sensors and monitoring instruments for measurement of pressure and temperature. The industrial pressure transmitter EPN 8288, like its reliable predecessor the EPN 8298, has an exceptional ruggedness and a strong thin-film-on-steel sensor cell. The triple overpressure safety, a wide temperature range of up to 125°C and the marine certifications make the EPN 8288 the ideal solution for a wide variety of challenging applications.



Applications

- Shipbuilding
- Engine manufacturing
- Machine tools
- Hydraulics



Features

- Excellent long-term stability
- High resistance to over pressure
- Completely welded steel sensor system without additional seals
- Different accuracy classes

Technical Data

Measuring principle	Thin-film-on-steel	Media temperature	-40°C ... +125°C
Measuring range	0 ... 2.5 to 0 ... 600 bar 0 ... 30 to 0 ... 7500 psi	Ambient temperature	-40°C ... +125°C
Output signal	4 ... 20 mA, 0 ... 10 VDC	Approval / conformity	DNV-GL EU RO Mutual Recognition Type Approval Certificate
Accuracy @ 25°C typ.	± 0.5 % FS typ. ± 0.3 % FS typ.		

02/2019

Data sheet H72318d

Subject to change

Ordering information/type code

				8288 . XX			XX	XX	XX	XX	XX
Measuring range ¹⁾	Pressure measurement range [bar]	Over pressure [bar]	Burst pressure [bar]	Pressure measurement range [psi]	Over pressure [psi]	Burst pressure [psi]					
	0 ... 2.5	7.5	50	0 ... 30	90	700	G5				
	0 ... 4	12	60	0 ... 50	150	850	G6				
	0 ... 6	18	100	0 ... 100	300	1450	G7				
	0 ... 10	30	200	0 ... 150	450	2500	G8				
	0 ... 16	48	200	0 ... 200	600	2500	GA				
	0 ... 25	75	300	0 ... 250	750	2500	G9				
	0 ... 40	120	300	0 ... 300	900	4000	HA				
	0 ... 60	180	400	0 ... 400	1200	4000	H0				
	0 ... 100	300	500	0 ... 500	1500	4000	H1				
	0 ... 160	480	750	0 ... 1000	3000	5000	H2				
	0 ... 250	750	1000	0 ... 1500	4500	7000	H3				
	0 ... 400	1000	2000	0 ... 2000	6000	10000	H5				
	0 ... 600	1500	2500	0 ... 3000	9000	14500	G4				
				0 ... 5000	12500	21750	H4				
				0 ... 7500	18750	29000	H6				
	Sensor	Relative pressure, accuracy: 0.3 %; Material pressure connection and housing: 1.4542 (AISI630)						23			
Relative pressure, accuracy: 0.5 %; Material pressure connection and housing: 1.4542 (AISI630)						25					
Relative pressure, accuracy class: 0.3 %; Material pressure connection and housing: 1.4404 (AISI316L) ²⁾						33					
Relative pressure, accuracy class: 0.5 %; Material pressure connection and housing: 1.4404 (AISI316L) ²⁾						35					
Pressure connection	G1/4" male (Seal)							17			
	1/4" NPT male ³⁾							30			
	R1/4" male, DIN3858 ³⁾							19			
	1/2" NPT male ³⁾							51			
	M14x1.5 male DIN6149-2 ³⁾							31			
	G1/2" male (Manometer) ³⁾							11			
Electrical connection	Male electrical plug EN 175301-803-A (DIN43650-A), Mat. PA								05		
Output signal	Signal output	Load resistance	I (supply)	U (supply)							
	4 ... 20 mA	(U _{supply} -9 V) / 20 mA		9 ... 32 VDC					19		
	0 ... 10 VDC	> 5 kΩ	< 10 mA	15 ... 32 VDC					17		
Accessories	Seal FPM, -18°C ... +125°C										61
	Seal EPDM, -40°C ... +125°C										63
	Seal NBR, -25°C ... +100°C										83
	Pressure peak damping element ø 1.0 mm, material 1.4305 ⁴⁾										40
	Pressure peak damping element ø 0.4 mm, material 1.4305 (sensors 23, 25) resp. 1.4404 (sensors 33, 35) ⁴⁾										44
	Female electrical connector EN 175301-803-A (DIN43650-A)/NBR, -40°C ... +90°C										58
	Female electrical connector EN 175301-803-A (DIN43650-A)/Silicone, -40°C ... +125°C										56
	Special electrical connection: Pin 1 +, Pin 2 - (only for output signal 4 ... 20 mA and male electrical plug EN175301-803-A / DIN43650-A)										92
	Special electrical connection: Pin 1 Out, Pin 2 -, Pin 3 + (only for output 0 ... 10 VDC and male electrical plug EN175301-803-A / DIN43650-A)										98
	Special electrical connection: Pin 1 +, Pin 2 -, Pin 3 Out (only for output 0 ... 10 VDC and male electrical plug EN175301-803-A / DIN43650-A)										97
	Multiple packaging ⁵⁾										VM

¹⁾ Customized pressure ranges upon request

²⁾ Only for pressure ranges ≥ 0 ... 10 bar

³⁾ Upon request

⁴⁾ Not for pressure connection 11

⁵⁾ The order quantity must be a multiple of 50

Standard products (extra short lead time)

Product No.	Type Code	Pressure range [bar]	Over pressure max. [bar]	Signal output	Supply [VDC]
EPN2.5A	8288 75 2517 05 0000 0000 19 44 58 61	0 ... 2.5	7.5	4 ... 20 mA	9 ... 32
EPN4.0A	8288 76 2517 05 0000 0000 19 44 58 61	0 ... 4	12	4 ... 20 mA	9 ... 32
EPN6.0A	8288 77 2517 05 0000 0000 19 44 58 61	0 ... 6	18	4 ... 20 mA	9 ... 32
EPN10.0A	8288 78 2517 05 0000 0000 19 44 58 61	0 ... 10	30	4 ... 20 mA	9 ... 32
EPN16.0A	8288 79 2517 05 0000 0000 19 44 58 61	0 ... 16	48	4 ... 20 mA	9 ... 32
EPN25.0A	8288 80 2517 05 0000 0000 19 44 58 61	0 ... 25	75	4 ... 20 mA	9 ... 32
EPN40.0A	8288 81 2517 05 0000 0000 19 44 58 61	0 ... 40	120	4 ... 20 mA	9 ... 32
EPN60.0A	8288 82 2517 05 0000 0000 19 44 58 61	0 ... 60	180	4 ... 20 mA	9 ... 32
EPN100.0A	8288 83 2517 05 0000 0000 19 44 58 61	0 ... 100	300	4 ... 20 mA	9 ... 32
EPN160.0A	8288 85 2517 05 0000 0000 19 44 58 61	0 ... 160	480	4 ... 20 mA	9 ... 32
EPN250.0A	8288 74 2517 05 0000 0000 19 44 58 61	0 ... 250	750	4 ... 20 mA	9 ... 32
EPN400.0A	8288 84 2517 05 0000 0000 19 44 58 61	0 ... 400	1000	4 ... 20 mA	9 ... 32
EPN600.0A	8288 86 2517 05 0000 0000 19 44 58 61	0 ... 600	1500	4 ... 20 mA	9 ... 32

Specifications

Electrical Data	Output / supply voltage	4 ... 20 mA: 24 (9 ... 32) VDC 0 ... 10 VDC 24 (15 ... 32) VDC
	Rise time	Typ. 1 ms / 10 ... 90 % nominal pressure
	Switch-on-delay	100 ms
	Inverse-polarity protection, short-circuit strength @ 25°C during 5 min.	4...20 mA: to $U_s = 32$ VDC 0...10 VDC: to $U_s = 28$ VDC
	Environmental conditions	Media temperature
	Ambient temperature	-40°C ... +125°C
	Protection ¹⁾	IP65
	Humidity	IEC 60068-2-30 (damp heat, cyclic, 100 % RH @ +55°C)
	Vibration	15 g RMS (20...2000 Hz) acc.to EN 60068-2-64 25 g sin (10...2000 Hz), 1 oct./min, (1x @ 25°C) acc.to EN 60068-2-6
	Shock	500 g / 1 ms acc.to EN 60068-2-27
EMC Protection	Emission	EN/IEC 61000-6-3, IACS UR E10
	Immunity	EN/IEC 61000-6-2, IACS UR E10
Mechanical Data	Sensor (wetted parts)	1.4542 (AISI630)
	Pressure connection (wetted parts)	1.4542 (AISI630) or 1.4404 (AISI316L)
	Housing	1.4542 (AISI630) or 1.4404 (AISI316L)
	Sealing	FPM/EPDM/NBR
	Male electrical plug	See ordering information
	Weight	appr. 80 ... 110 g
	Mounting torque	25 Nm

¹⁾ See electrical connection

Accuracy

		Class 0.5 % Ordering No. 25/35	Class 0.3 % Ordering No. 23/33
TEB @ -25 ... +85°C	[% FS typ.]	± 1.75	± 0.5
Accuracy @ +25°C	[% FS typ.]	± 0.5	± 0.3
NLH @ +25°C (BSL)	[% FS typ.]	± 0.2	± 0.1
TC zero point and span	[% FS/K typ.]	± 0.03	± 0.005
Long term stability 1 year @ +25°C	[% FS typ.]	± 0.1	± 0.1

Class 0.5 %

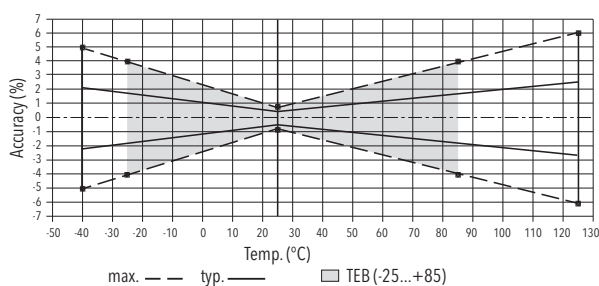

Class 0.3 %

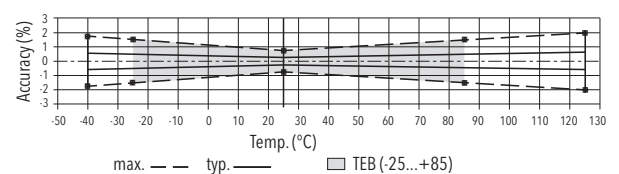

Dimensions

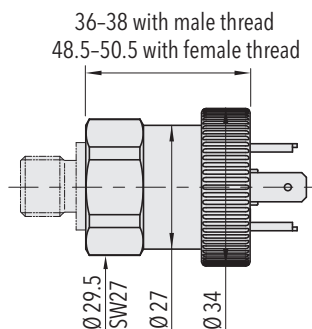

8288.XX.XXXX.05.XX.XX

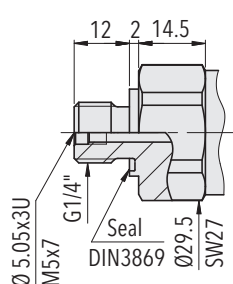

8288.XX.XX17.XX.XX.XX

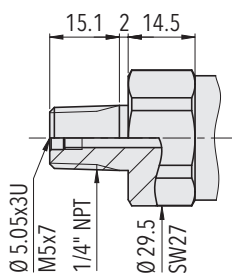

8288.XX.XX30.XX.XX.XX

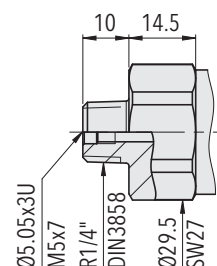

8288.XX.XX19.XX.XX.XX

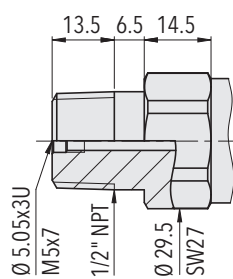

8288.XX.XX51.XX.XX.XX

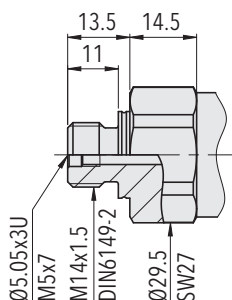

8288.XX.XX31.XX.XX.XX

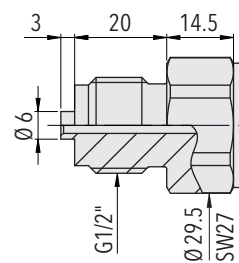

8288.XX.XX11.XX.XX.XX

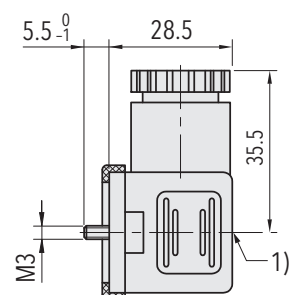

1) Tightening torque 50...60 Ncm

8288.XX.XXXX.XX.XX.58

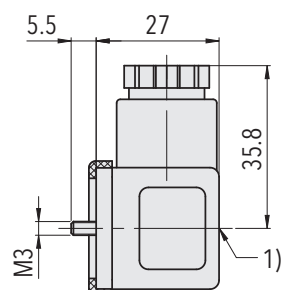

1) Tightening torque 50...60 Ncm

8288.XX.XXXX.XX.XX.56

Electrical connection

		Protection / electrical connection		
		IP65, IP67*)		
		Industrial standard EN175301-803A **)		
		05		
Output signal	<p>8288.xx.xxxx.xx.19</p>	Standard		
		2 1 ⊕	92 1 2 ⊕	
	<p>8288.xx.xxxx.xx.17</p>	Standard	98	97
	for DC	2 3 1 ⊕	3 1 2 ⊕	1 3 2 ⊕

*) Provided female connector is mounted according to instructions

**) Ventilation via male electric plug

***) Only female electrical plug with shield connection

Additional information

Documents		
	Data sheet	www.trafag.com/H72318
	Instructions	www.trafag.com/H73317
	Flyer	www.trafag.com/H70693